

AD-Servo Series Techical Details

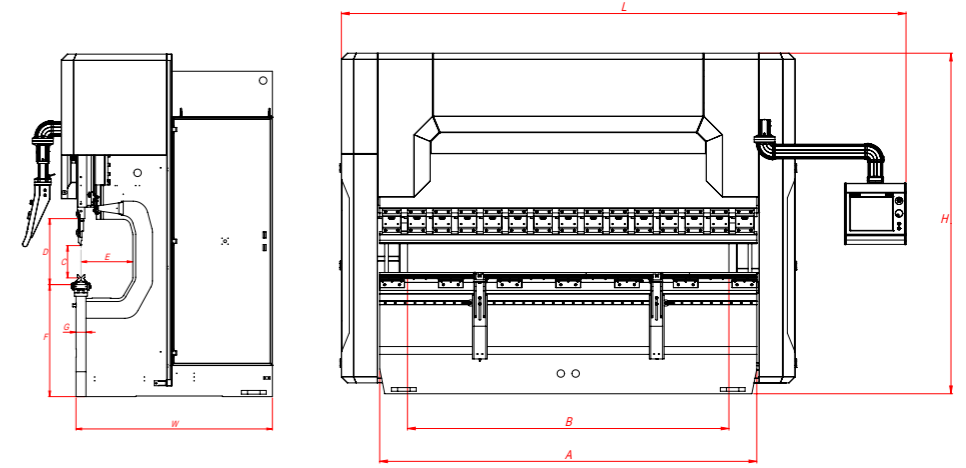

AD-Servo Series	Bending Force	Bending Length	Distance Between Columns	Stroke	Daylight	Throat Depth	Table Height	Table Width	Working Speed	
									Y Rapid Speed	Y Working Speed
	Ton	mm	mm	mm	mm	mm	mm	mm	mm/sn.	mm/sn.
		A	B	C	D	E	F	G		
AD-Servo 25100	100	2550	2200	265	530	450	900	104	200	10
AD-Servo 30100	100	3050	2600	265	530	450	900	104	200	10
AD-Servo 30135	135	3050	2600	265	530	450	900	104	200	10
AD-Servo 30175	175	3050	2600	265	530	450	900	104	200	10
AD-Servo 30220	220	3050	2600	265	530	450	900	104	200	12
AD-Servo 30320	320	3050	2600	365	630	450	900	154	160	10
AD-Servo 37175	175	3700	3100	265	530	450	900	104	200	10
AD-Servo 37220	220	3700	3100	265	530	450	900	104	200	12
AD-Servo 40175	175	4050	3600	265	530	450	900	104	200	10
AD-Servo 40220	220	4050	3600	265	530	450	900	104	200	12
AD-Servo 40320	320	4050	3600	365	630	450	900	154	160	10
AD-Servo 60220	220	6050	5100	265	530	450	1100	154	200	12
AD-Servo 60320	320	6050	5100	365	630	450	1100	154	160	10

* 750 mm throat depth
 ** 750 - 1000 - 1250 mm throat depth
 Machines set according to optimum values.

Y Return Speed	X Axes Working Speed	R Axes Working Speed	R Axes Working Distance	X Axes Distance			Motor Power	Consumption Rate	Oil Tank Capacity	Length	Width	Height	Weight Approx.
				650	750	1000							
(mm/sn.)	(mm/sn.)	(mm/sn.)	(mm)					(kWh)	(Lt)	(mm)	(mm)	(mm)	(kg)
										L	W	H	
200	500	350	250	S	-	O	4 x 2	2,1	75	3800	1670	2850	7800
200	500	350	250	S	-	O	4 x 2	2,1	75	4200	1670	2850	8500
200	500	350	250	S	-	O	4 x 2	2,65	75	4200	1680	2850	9580
200	500	350	250	S	-	O	4 x 2	3,38	75	4250	1700	2850	10900
180	500	350	250	S	-	O	11 x 2	5,2	80 x 2	4250	1770	3000	12600
160	500	350	250	S	-	O	11 x 2	7,2	80 x 2	4300	1820	3330	17100
200	500	350	250	S	-	O	4 x 2	3,38	75	4950	1700	3000	11750
180	500	350	250	S	-	O	11 x 2	5,2	80 x 2	4950	1770	3000	14440
200	500	350	250	S	-	O	4 x 2	3,38	75	5250	1700	2850	12780
180	500	350	250	S	-	O	11 x 2	5,2	80 x 2	5250	1770	3000	14750
160	500	350	250	S	-	O	11 x 2	7,2	80 x 2	5300	1910	3330	20000
180	350	300	250	-	S	O	11 x 2	5,2	80 x 2	7500	1770	3350	20800
160	350	300	250	-	S	O	11 x 2	7,2	80 x 2	7500	1910	3350	29000

S : Standard

O : Option