

# AD-S Series Technical Details

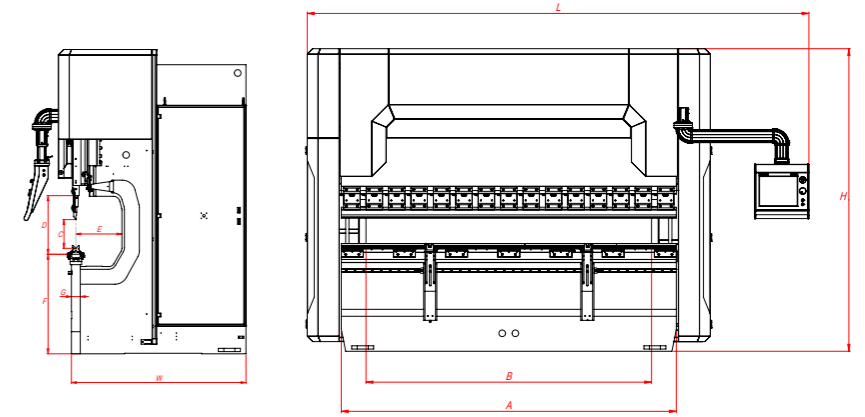

AD-S Series	Bending Force Ton	Bending Length mm A	Distance Between Columns mm B	Stroke mm C	Daylight mm D	Throat Depth mm E	Table Height mm F	Table Width mm G	Working Speed	
									Y Rapid Speed mm/sec	Y Working Speed mm/sec
									AD-S 1260	60
AD-S 2060	60	2050	1700	265	530	450	900	104	200	10
AD-S 25100	100	2550	2200	265	530	450	900	104	180	10
AD-S 30100	100	3050	2600	265	530	450	900	104	180	10
AD-S 30135	135	3050	2600	265	530	450	900	104	160	10
AD-S 30175	175	3050	2600	265	530	450	900	104	160	10
AD-S 30220	220	3050	2600	265	530	450	900	104	140	10
AD-S 30320	320	3050	2600	365	630	450	900	154	160	10
AD-S 37175	175	3700	3100	265	530	450	900	104	140	10
AD-S 37220	220	3700	3100	265	530	450	900	104	160	10
AD-S 40175	175	4050	3600	265	530	450	900	104	160	10
AD-S 40220	220	4050	3600	265	530	450	900	104	160	10
AD-S 40320	320	4050	3600	365	630	450	900	154	160	10
AD-S 40400	400	4050	3400	365	630	450	1050	154	140	8
AD-S 40600	600	4050	3100	365	700	510	990	154	80	7
AD-S 60220	220	6050	5100	265	530	410	1050	154	140	10
AD-S 60320	320	6050	5100	365	630	450	1100	154	140	10
AD-S 60400	400	6050	5100	365	630	450	1220	154	120	8
AD-S 60600	600	6050	5100	365	700	510	990	154	80	7
AD-S 60800	800	6050	5100	400	700	610	800	400	70	6
AD-S 70800	800	7050	5100	400	700	610	800	400	80	7
AD-S 701000	1000	7050	5100	500	800	610	800	400	70	5
AD-S 701250	1250	7050	5100	500	800	610	900	400	70	7
AD-S 80800	800	8050	6400	400	700	610	800	400	80	7
AD-S 801000	1000	8050	6400	500	800	610	800	400	70	5
AD-S 801250	1250	8050	6400	500	800	610	900	500	70	7
AD-S 801600	1600	8100	6400	500	1000	610	900	500	70	6
AD-S 802000	2000	8100	6400	600	1000	750	950	500	70	6

Machines set according to optimum values.

Y Return Speed mm/sec	X Axes Working Speed mm/sec	R Axes Working Speed mm	R Axes Working Distance mm	X Axes Distance			Motor Power kW	Length mm L	Width mm W	Height mm H	Weight Approx. kg
				650	750	1000					
				110	500	350					
110	500	350	250	S	-	O	7,5	3200	1550	2850	5600
120	500	350	250	S	-	O	11	3800	1670	2850	7800
120	500	350	250	S	-	O	11	4200	1670	2850	8500
120	500	350	250	S	-	O	15	4200	1680	2850	9580
100	500	350	250	S	-	O	18,5	4250	1700	2850	10900
140	500	350	250	S	-	O	22	4250	1770	3000	12600
140	500	350	250	S	-	O	37	4300	1820	3330	17100
100	500	350	250	S	-	O	18,5	4950	1700	3000	11750
120	500	350	250	S	-	O	22	4950	1770	3000	14440
140	500	350	250	S	-	O	18,5	5250	1700	2850	12780
140	500	350	250	S	-	O	22	5250	1770	3000	14750
140	500	350	250	S	-	O	37	5300	1910	3330	20000
120	350	300	250	-	S	O	37	5750	2110	3640	27760
80	350	300	250	-	S	O	45	5650	2250	3935	40500
120	350	300	250	-	S	O	22	7500	1770	3350	20800
120	350	300	250	-	S	O	37	7500	1910	3550	29000
100	350	300	250	-	S	O	37	7500	2110	3810	34600
80	350	300	250	-	S	O	45	7600	2650	3950	52500
80	300	250	250	-	S	O	55	8050	3200	4250	72000
70	300	250	250	-	S	O	55	8700	3200	4250	79500
60	300	250	250	-	S	O	55	8800	3250	5900	95500
70	300	250	250	-	S	O	90	8800	3250	6400	110000
70	300	250	250	-	S	O	55	9800	3200	4250	85000
60	300	250	250	-	S	O	55	10000	3250	5900	102000
70	300	250	250	-	S	O	90	10000	3250	6400	135000
70	300	250	250	-	S	O	90	10100	3500	6000	163000
60	300	250	250	-	-	S	110	10500	4350	7000	249000

S : Standard

O : Option